

Mounting instructions

PV mounting systems for pitched roofs

PV mounting systems for pitched roofs
Mounting instructions

OBO Bettermann Holding GmbH & Co. KG

P.O. Box 1120
58694 Menden
GERMANY

Technical Office

Tel.: +49 (0)2373 89-1300

technical-office@obo.de

www.obo-bettermann.com

Stand 11/2024

230075.02

Building Connections



Table of contents

1	About these instructions	5
1.1	Target group	5
1.2	Relevance of these instructions	5
1.3	Types of warning information	5
1.4	Basic standards and regulations	5
1.5	Applicable documents	6
2	Intended use	6
3	Safety	6
3.1	General safety information	6
3.2	Personal protective equipment	7
4	Necessary tools	7
5	System overview	8
6	Installation	10
6.1	Preparations for mounting	10
6.2	Mounting roof hooks	12
6.2.1	Assembling roof hooks	12
6.2.2	Adjusting the height, depth or lateral position of the roof hook	13
6.2.3	Screwing on a roof hook	14
6.3	Using a support profile	18
6.4	Fastening PV modules with universal clamps	19
6.4.1	Mounting the universal clamp as an end clamp on the left	19
6.4.2	Mounting the universal clamp as a middle clamp	22
6.4.3	Mounting the universal clamp as an end clamp on the right	23
6.5	Replacing the PV module	24
6.6	Fastening PV modules to Lehmann on-roof module holders	25
6.7	Mounting the protective cap	26
6.8	Integrating the system into the equipotential bonding and/or lightning protection system	27
6.9	Mounting the support profile in a lengthwise direction	29
6.10	Connecting support profiles transversely	30
7	Maintaining the system	31
8	Dismantling the system	31
8.1	Dismantling a support profile	31
9	Disposing of the system	32
10	Technical data	32

1 About these instructions

1.1 Target group



These instructions are intended for specialists and/or instructed technical personnel (e.g. roofers, solar panel installers, engineers, architects, construction managers, mounting engineers, installation engineers), who have been trained in the mounting of photovoltaic systems and have been charged with the mounting of PV mounting systems.

Only have electrical work, such as the connection and earthing of the systems, carried out by specialist personnel with electrical training.

1.2 Relevance of these instructions

These instructions are based on the standards valid at the time of compilation (February 2024).

Please read the instructions carefully before starting mounting. We will not accept any warranty claims for damage and liability caused through non-observance of these instructions.

Any images are intended merely as examples. Mounting results may look different.

In these instructions, cables and lines are referred to simply as cables.

1.3 Types of warning information



Type of risk!

Shows a risky situation. If the warning information is not observed, then serious or fatal injuries may occur.

ATTENTION

Type of risk!

Shows a risky situation. If the safety instruction is not observed, then damage to the product or the surroundings may occur.

Note!

Indicates important information or assistance.

1.4 Basic standards and regulations

- VDI 6012
- DIN EN 62305 (VDE 0185-305)
- DIN VDE 0100-712
- DIN EN 61643-32

1.5 Applicable documents

- The declarations of conformity are linked to the products at www.obo-bettermann.com.

2 Intended use

The photovoltaic mounting systems for pitched roofs are used for the mounting of photovoltaic modules with a height of 30–50 mm on tiled roofs with an inclination of 10–70°. The support profiles for the PV modules may be connected up to a maximum length of 20 m, in order to guarantee thermal separation. The minimum distance between two unconnected support profiles must be at least 50 mm in length. The mounting systems are not intended for securing people with belts or ropes during roofing work.

The mounting systems are not designed for any other purpose than the one described here. If the photovoltaic mounting systems are used for another purpose, any liability, warranty or damage claims shall be rendered null and void.

3 Safety

3.1 General safety information

Observe the following general safety information:

- It must be ensured that the planned PV system is intended for the load capacity of the roof. If necessary, consult a statics expert.
- The PV system must be matched to the local wind and snow load zones. Design only according to the planning using the OBO Construct app or a technical planner.
- The construction site must be protected against falling objects.
- Mounting must be carried out by at least 2 people.
- The people working must be protected as there is the risk of falling when working high above the ground.
- When working on the roof, care must be taken to avoid damaging the insulation of the roof.
- Contact with electrical current can lead to an electric shock. Electrical work may only be performed by qualified specialists.
- Protective clothing must be worn as there is the danger of cutting from sharp profile edges.

3.2 Personal protective equipment

List of personal protective equipment to be used:



Use hand protection



Wear safety shoes



Wear eye protection



Use catch protection

4 Necessary tools

List of tools to be used:

- Folding yardstick
- Pencil
- Angle grinder or tile and tray support grinder
- Battery-operated screwdriver (Torx 30/40)
- Torque spanner (Torx 30/40)
- Screwdriver (Torx 30/40)
- Hammer

5 System overview

The photovoltaic mounting systems (PV mounting systems) for pitched roofs consist of roof hooks, aluminium support profiles and universal clamps. The height and lateral position of the roof hooks are infinitely adjustable, in order to compensate for any unevenness in the roof construction. The roof hooks are screwed to the rafters with wafer-head screws. The support profiles are snapped onto the roof hooks without screws. The PV modules are located on the support profiles and are clamped on with universal clamps, which can be used on the outer side as end clamps and, between two modules, as centre clamps.

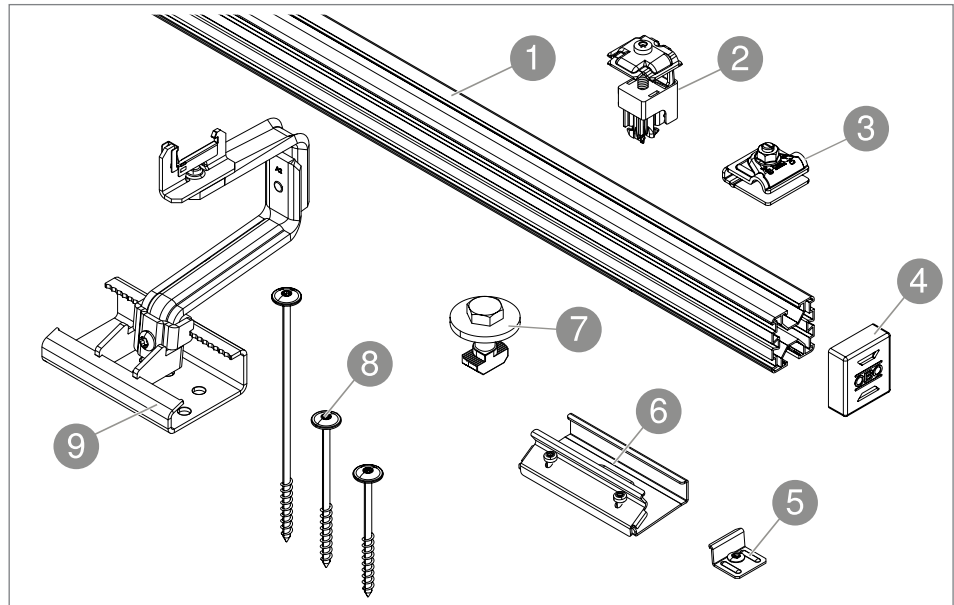

Fig. 1: System overview

Designation	Type	Function	
1	Support profile	TP 45/2350 ALU	Support and mounting rail for PV modules
2	Universal clamp	KLU A2/KLU A2 S	Fastening of PV modules on support profile
3	Universal earthing terminal PV	249 PV10 6-50V2A	Creation of equipotential bonding
4	End cap	EK 45 G/ EK 45 G S	Protection against injuries and ingress of dirt
5	Cross-connectors	KV 45 DD	Cross-connection of support profiles
6	Straight connector	LV 45 DD	Straight connection of support profiles
7	Bolt with hammer nut	SKS HM	Fastening of support profile to on-roof module of make Lehmann
8	Flange head	TKS 8x100 A2	Fastening of roof hooks on rafters/ counter slats
		TKS 8x120 A2	
		TKS 8x200 A2	
9	Roof hook, universal	DHU A2	Fastening on rafters/counter slats, support profile seat

Tab. 1: System overview

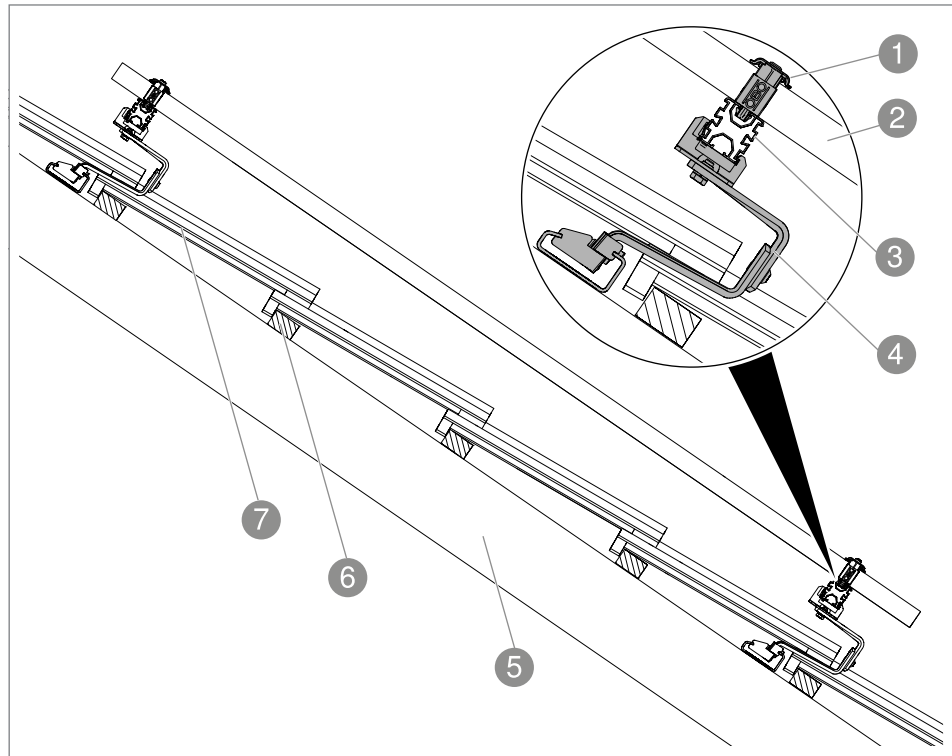

Fig. 2: System structure, side view

Component	
1	Universal clamp
2	PV module
3	Support profile
4	Roof hook
5	Rafters
6	Roof slats
7	Roofing tiles

Tab. 2: Overview, roof structure

6 Installation

The number and spacing of the roof hooks and modules are specified by the roof assignment plan from the planner/statics engineer and/or the OBO Construct app. Before starting mounting, it must be ensured that the roof assignment plan can be implemented and that the intended mounting points for the roof hooks match the spacings of the rafters.

6.1 Preparations for mounting

1. Identify the mounting points of the roof hooks according to the roof assignment plan.

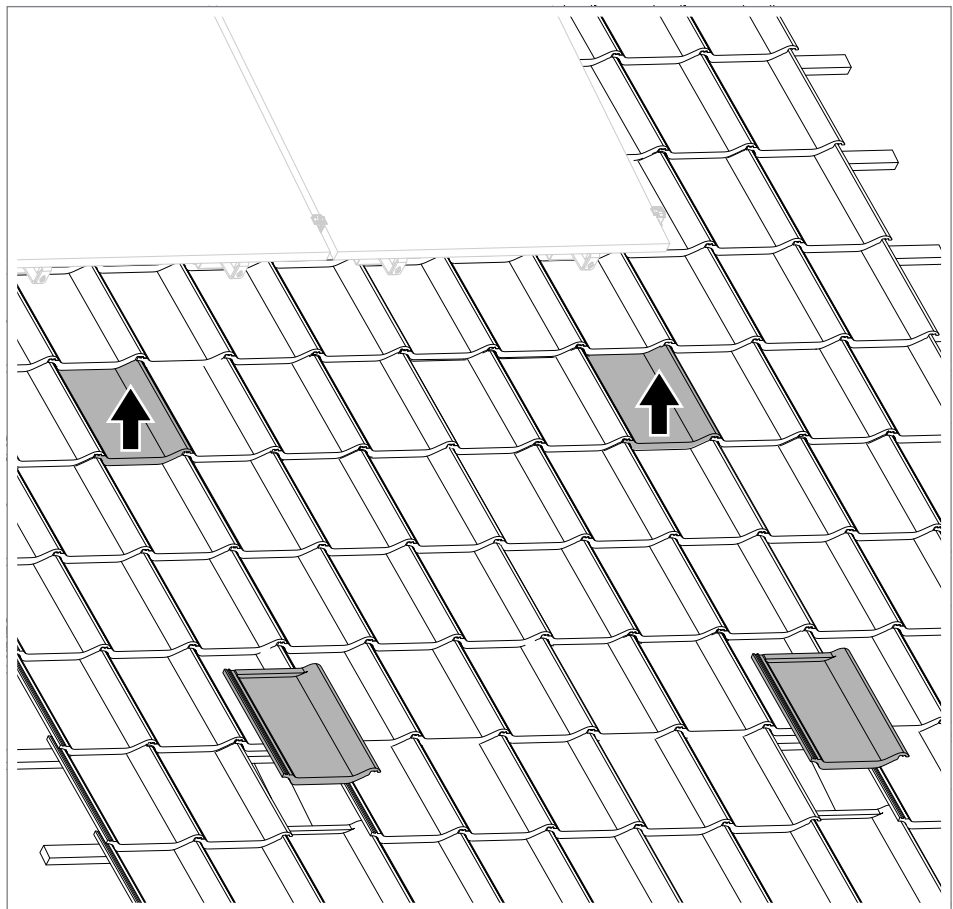

Fig. 3: Removing roof tiles

2. Remove or move roof tiles at the appropriate locations.

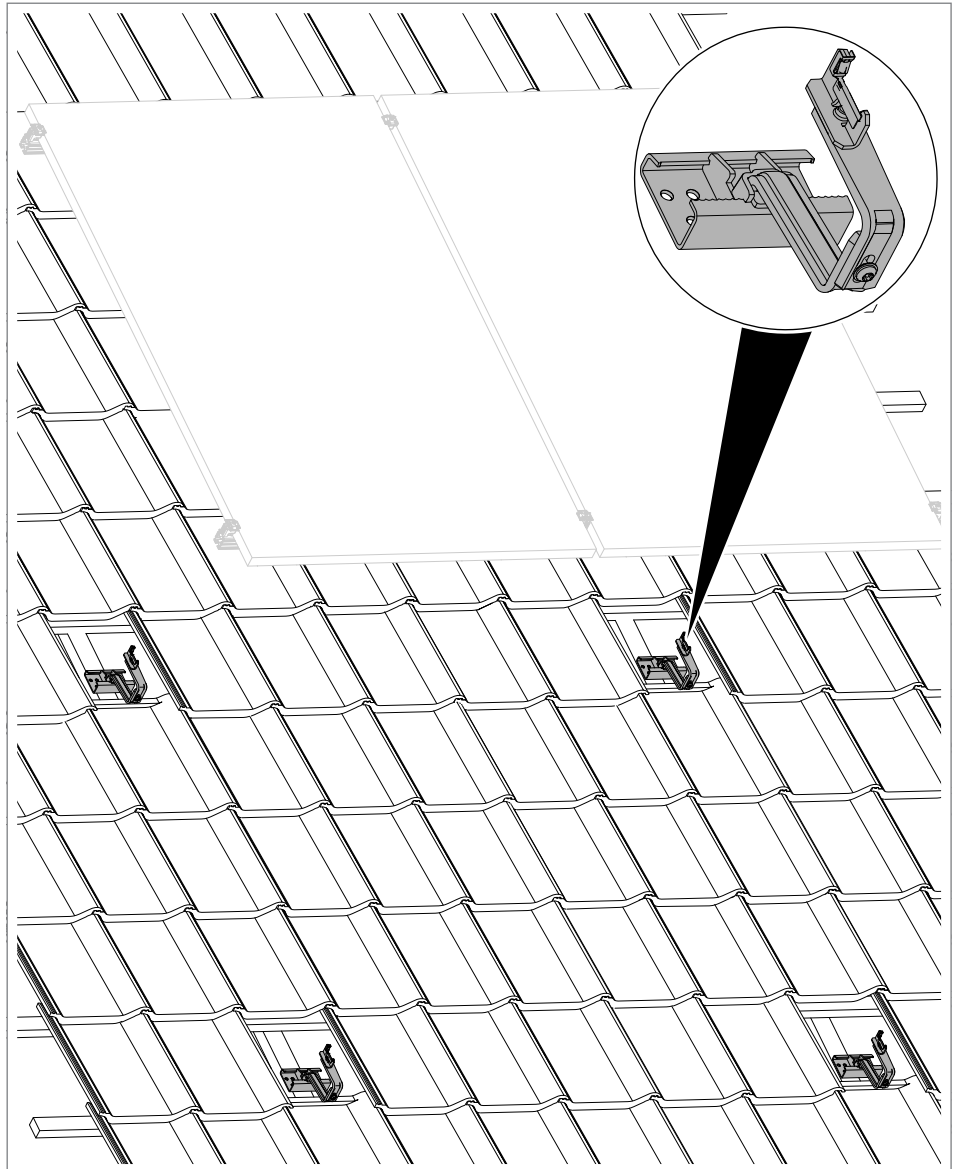

Fig. 4: Positioning roof hooks

3. Roughly position the roof hooks.

6.2 Mounting roof hooks

The roof hooks are screwed to the rafters with wafer-head screws. Depending on the strength of the slats, three different lengths of wafer-head screws are available. The screws should be at least 100 mm long. The roof hooks can be adjusted in terms of height and depth or laterally, e.g. to compensate for any unevenness in the roof construction.

ATTENTION

Unstable construction!

If an insufficient number of roof hooks is mounted, the roof hooks may deform and the construction becomes more susceptible to loads from wind turbulences. To avoid an unstable construction, all the roof hooks specified by the planning must be mounted.

6.2.1 Assembling roof hooks

The roof hook is supplied in two parts and must be assembled before roof mounting.

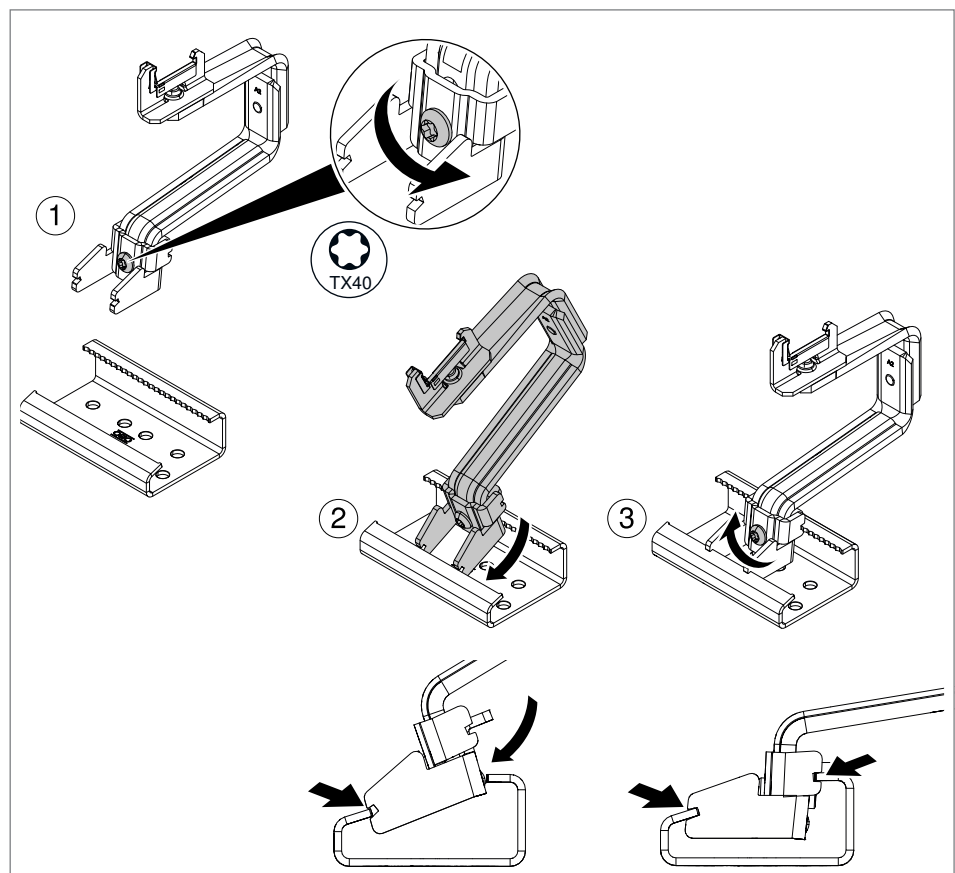

Fig. 5: Assembling roof hooks

1. Slightly unscrew the screw on the roof hook cover ①.
2. Insert the roof hook cover in the roof hook base ②.
3. Tighten the screw on the roof hook cover ③.

6.2.2 Adjusting the height, depth or lateral position of the roof hook

The height, depth and lateral position of the roof hook can be adjusted by unscrewing the appropriate screw.

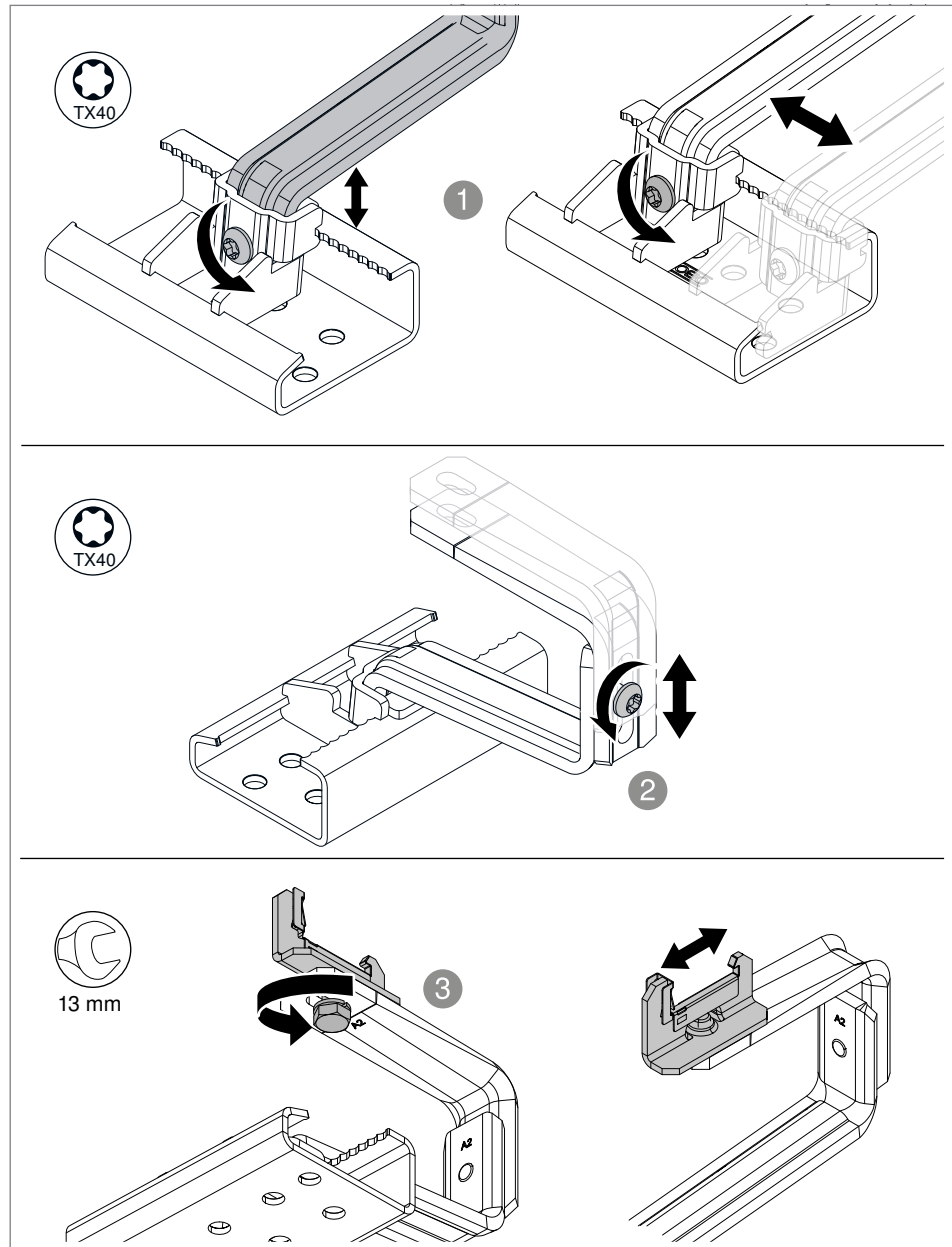

Fig. 6: Adjusting the roof hook

	Height adjustment	Tightening torque in Nm
1	Height adjustment, lateral adjustment	25 Nm
2	Height adjustment	20 Nm
3	Depth adjustment	20 Nm

1. Loosen the appropriate screw.
2. Adjust the height, depth or lateral position of the roof hook.
3. Tighten the screw, see table for tightening torque.

6.2.3 Screwing on a roof hook

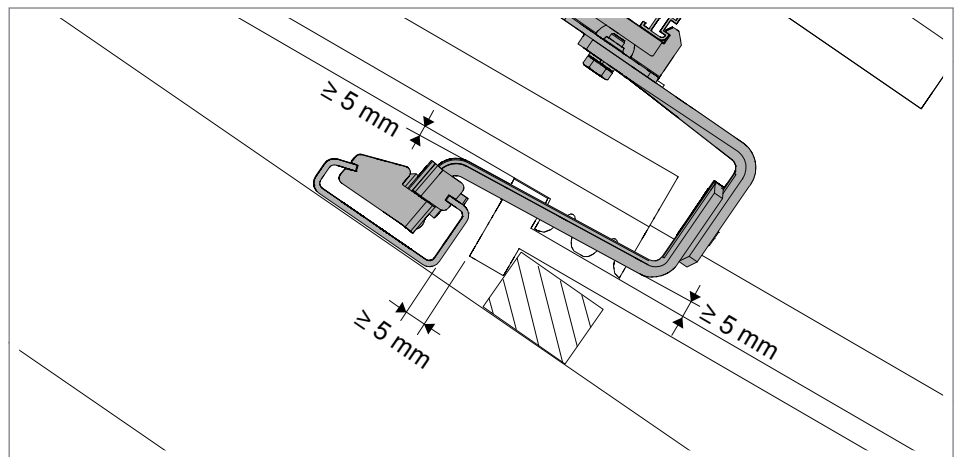

Fig. 7: Minimum spacings of roof hooks to tiles

ATTENTION

Risk of breakage!

Roof hooks pressing on roof tiles can cause tiles to break and cause damage, such as water permeation. To avoid damage to the roof tiles from roof hooks, the roof tiles must be recessed in the area of a roof hook and a minimum spacing of 5 mm maintained between the hook and tiles.

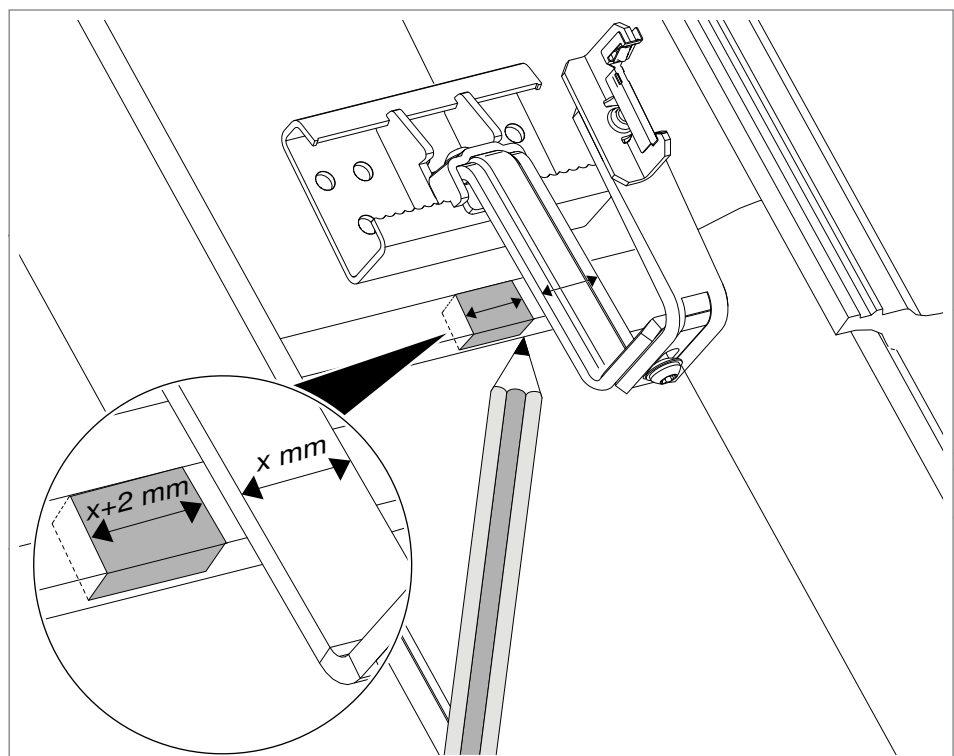

Fig. 8: Drawing on the recess

1. Draw on the tiles for the recess.

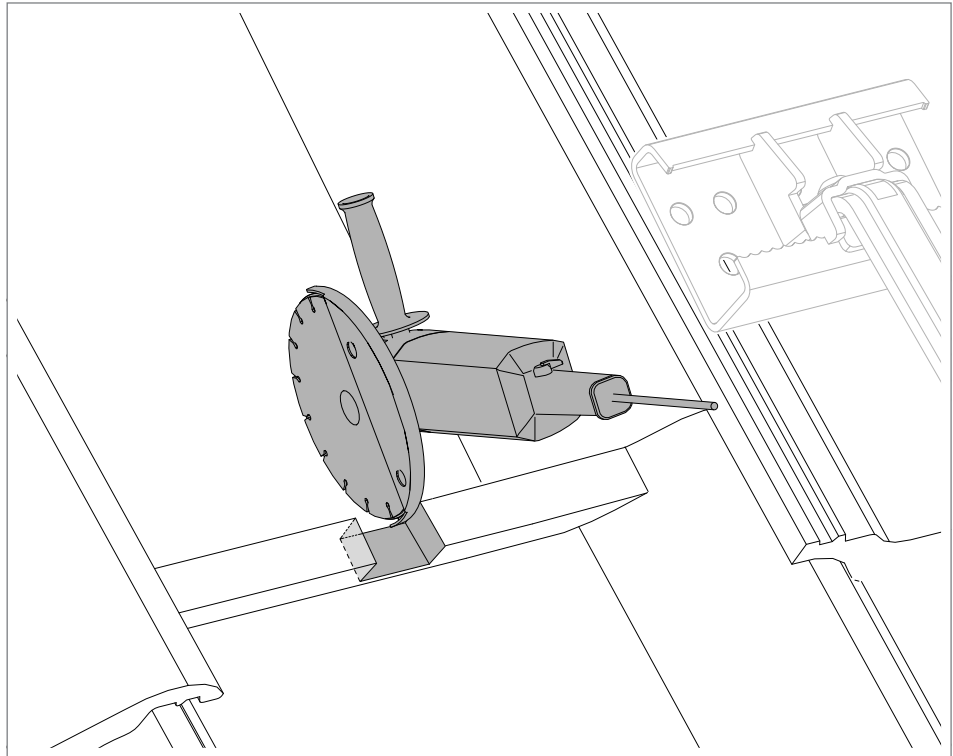

Fig. 9: Recessing tiles

2. Using an angle grinder or tile and tray support grinder, recess the tiles.

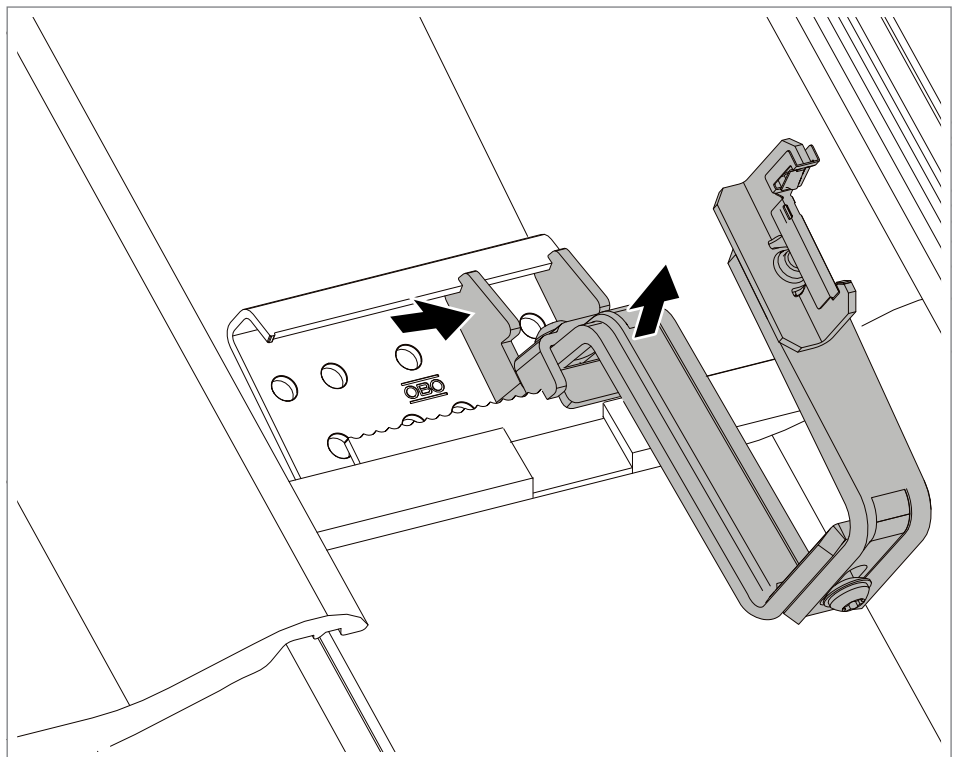

Fig. 10: Positioning the roof hook on rafters

3. Adjust the roof hook to be able to screw it to rafters.

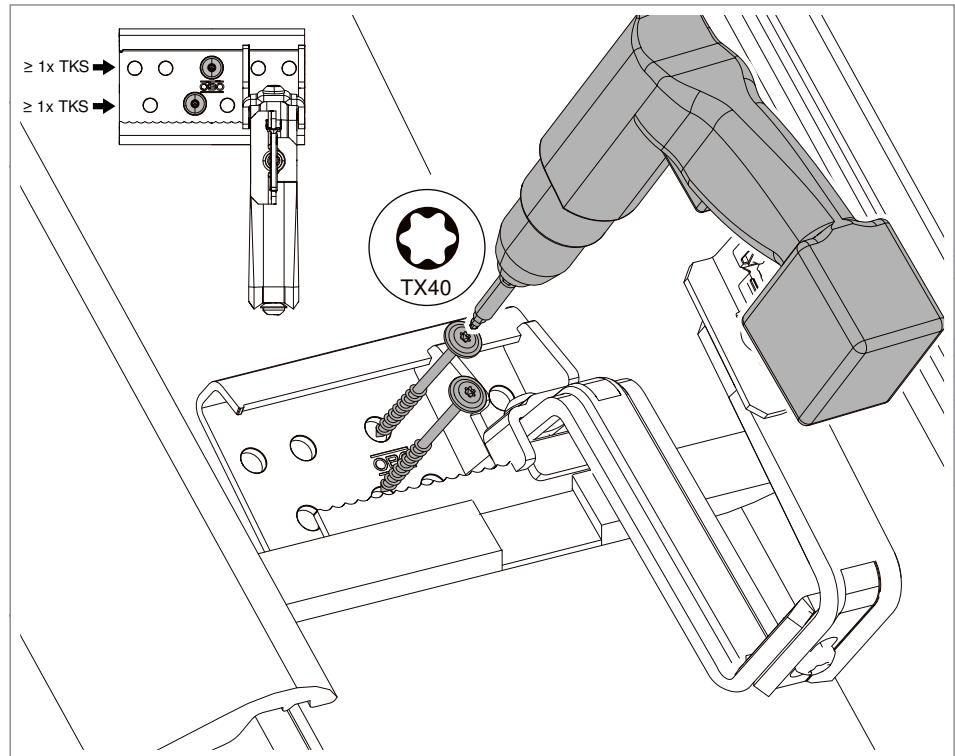

Fig. 11: Screwing on a roof hook

4. Screw the roof hook on with at least one wafer-head screw for each row of drill holes, see the specifications in the OBO Construct app.

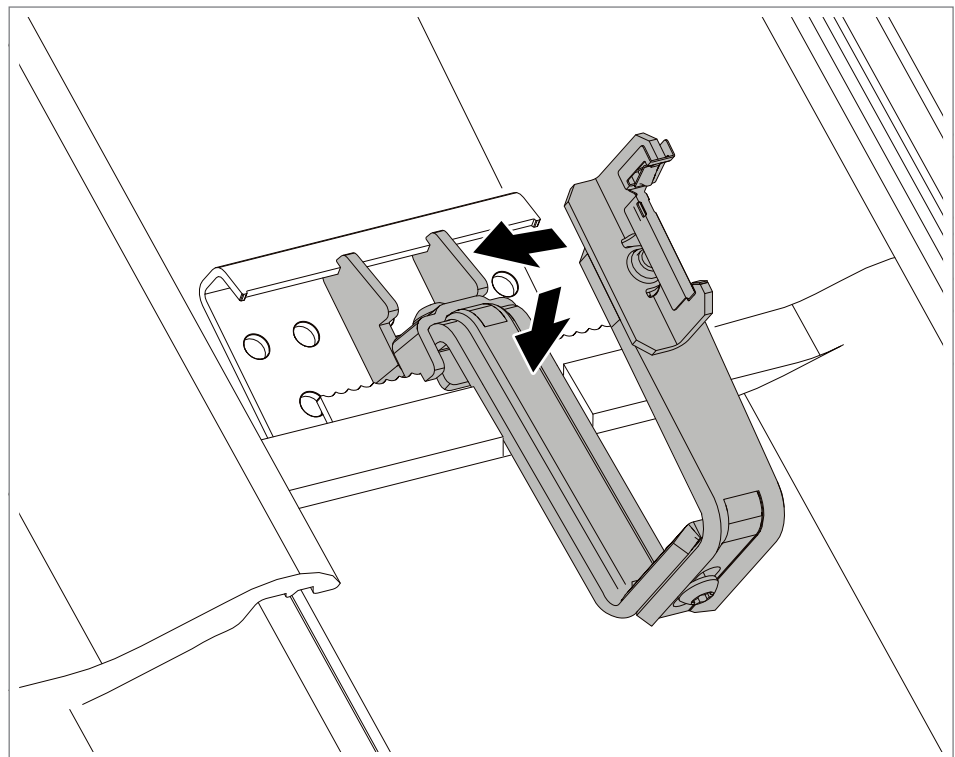

Fig. 12: Adjusting the roof hook

5. Finally, adjust the roof hook, observing a minimum distance of 5 mm to the tiles.

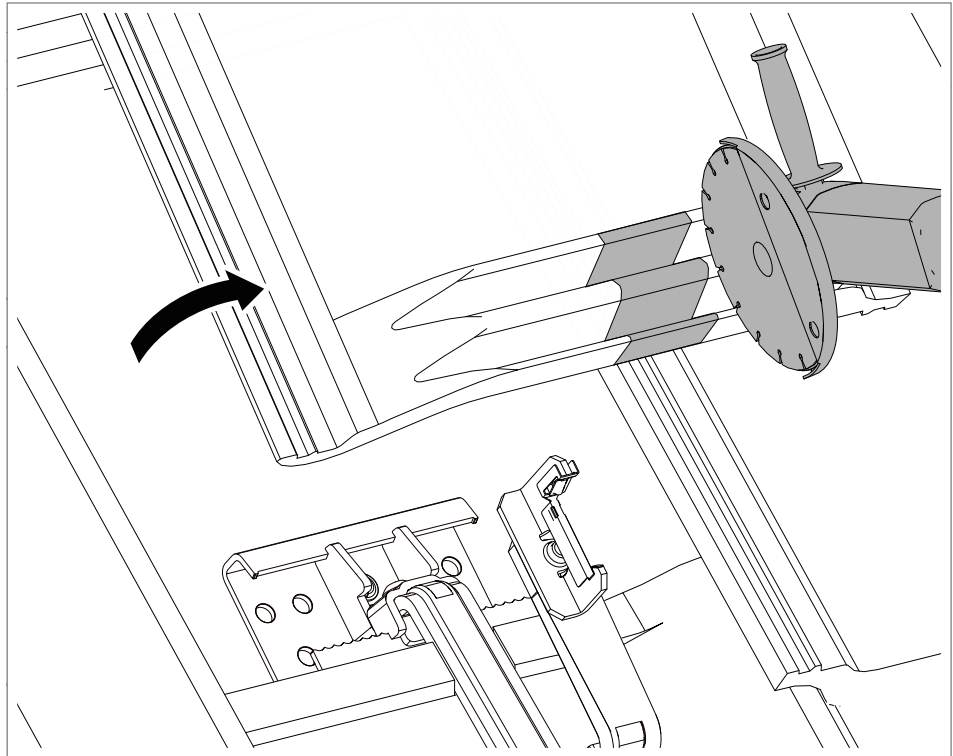

Fig. 13: Recess the underside of any tiles on top

6. Depending on the tile type, it may be necessary to recess the underside of the tile on top as well.
7. Align and mount all other necessary roof hooks.

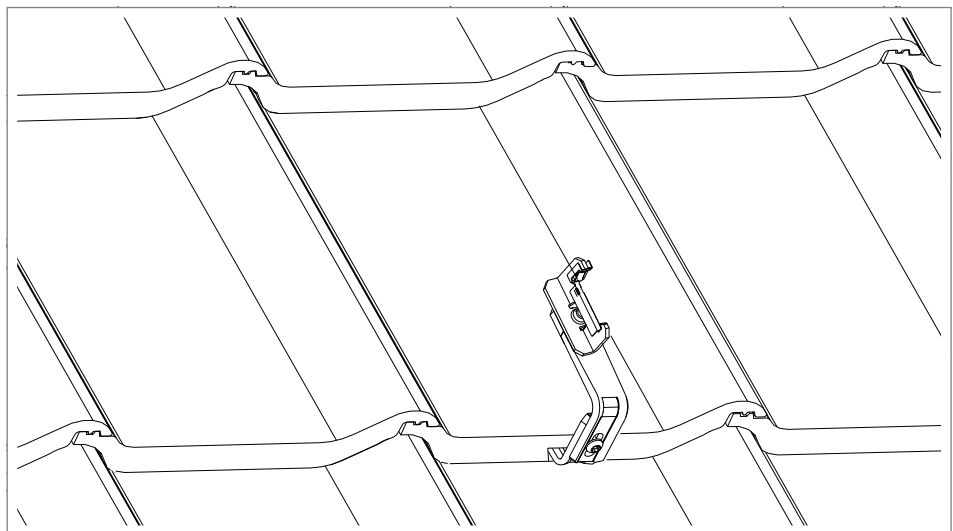

Fig. 14: Laying tiles

8. Relay the tiles.

6.3 Using a support profile

CAUTION**Risk of damage!**

The support profile has an integrated anti-slip mechanism. If an attempt is made to move the support profile after engaging, this can lead to damage to roof hooks and tiles. Position the support profile correctly before engaging. Any already engaged support profiles must be released again to move them.

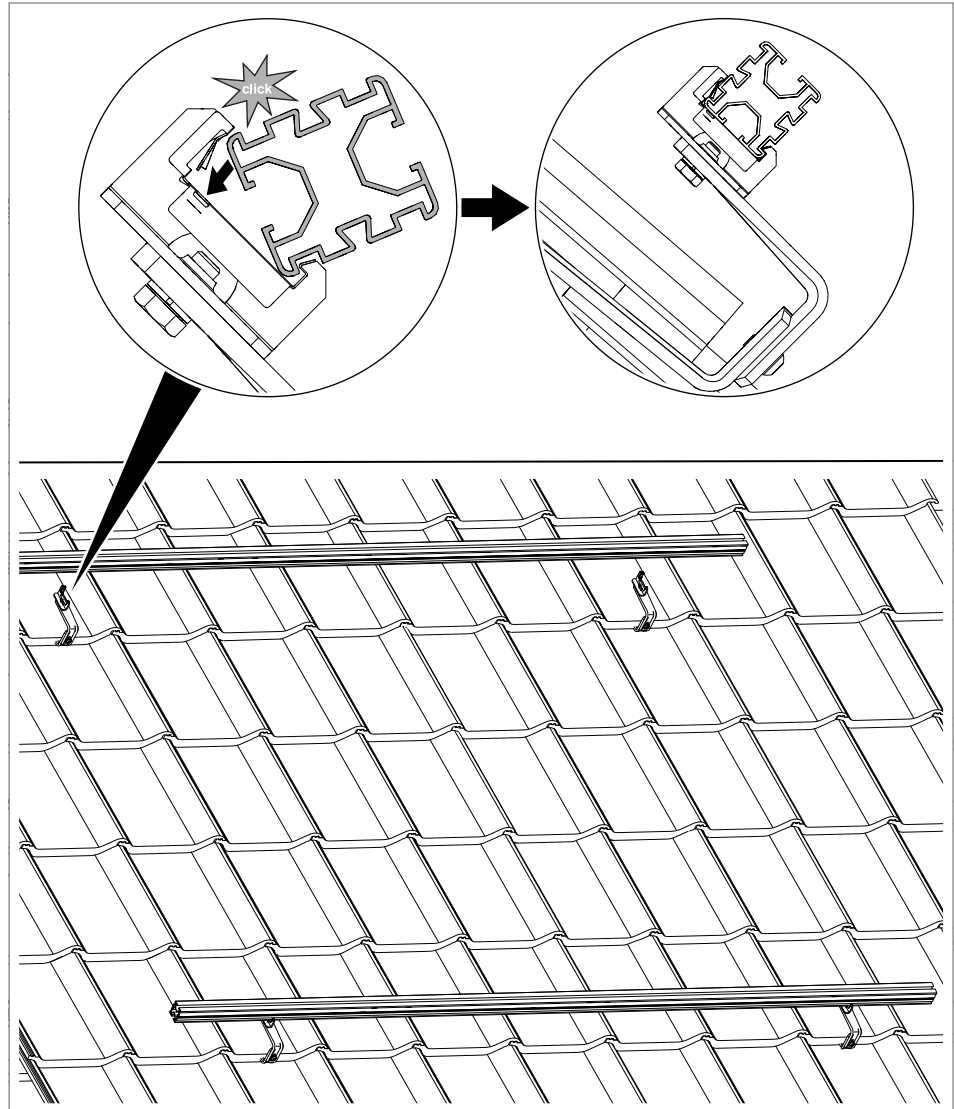

Fig. 15: Mounting support profiles

1. Insert the support profile into the seat of the ceiling hook at a slight angle and push it horizontally into the necessary position.
2. Engage the support profile.
3. Insert all the remaining support profiles.

6.4 Fastening PV modules with universal clamps

The PV modules are located on the support profiles and are clamped to the long outer edges with four universal clamps per module. The universal clamps are used as end clamps on the outer edges of the outer PV modules. In the case of two modules adjacent to each other, the universal clamps are used as middle clamps and one universal clamp each clamps both modules to the support profile.

6.4.1 Mounting the universal clamp as an end clamp on the left

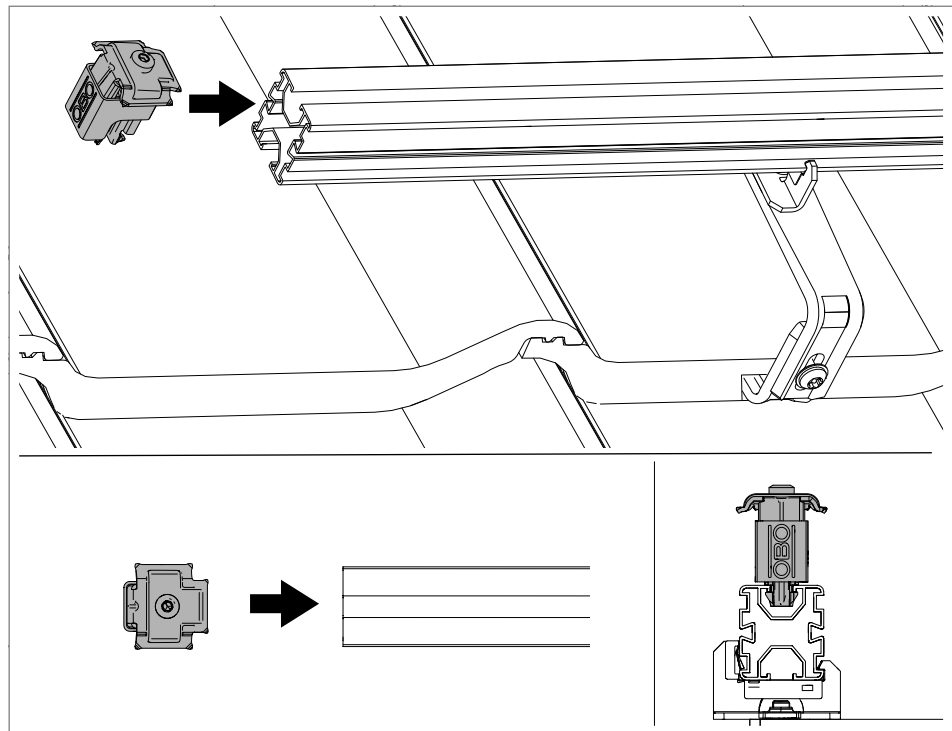

Fig. 16: Pushing the universal clamps in on the left as an end clamp

1. Push the universal clamps into the support profile from the left. The “OBO” label points outward.

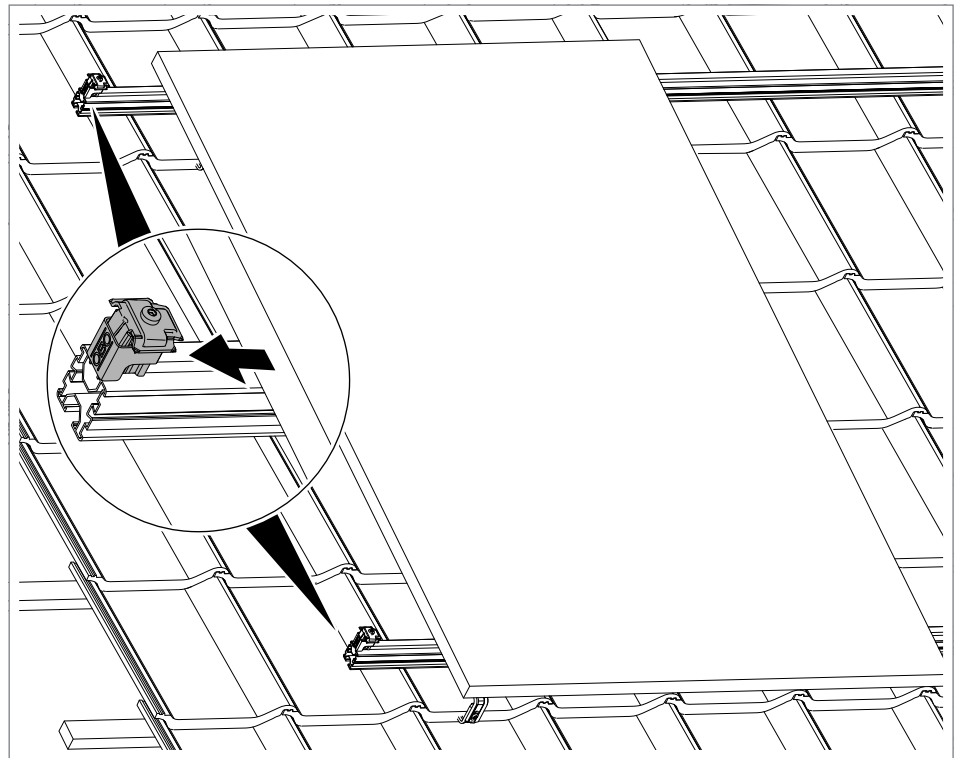

Fig. 17: Attaching the PV module

2. Place the PV module on the support profiles and push it up to the universal clamps.

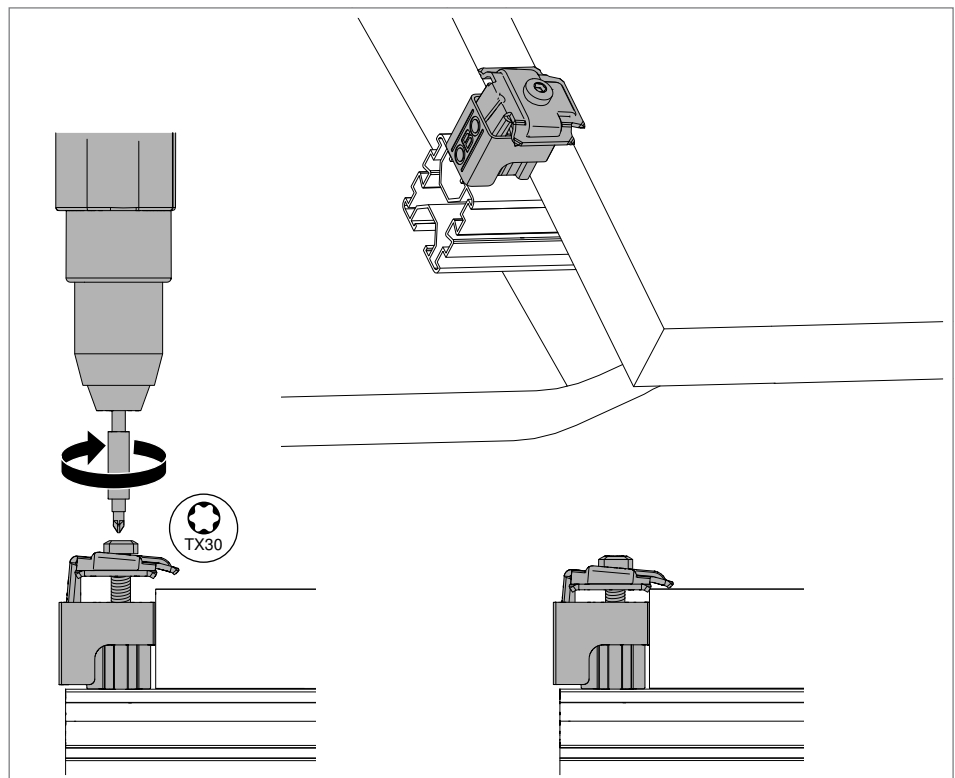

Fig. 18: Screwing the universal clamps in on the left as an end clamp

3. Screw the universal clamps to the outer edge of the module with 6 Nm.

6.4.2 Mounting the universal clamp as a middle clamp



Fig. 19: Using universal clamps as a middle clamp

1. Push the universal clamp into the rail from above. The “OBO” label points to the top or bottom edge of the module.

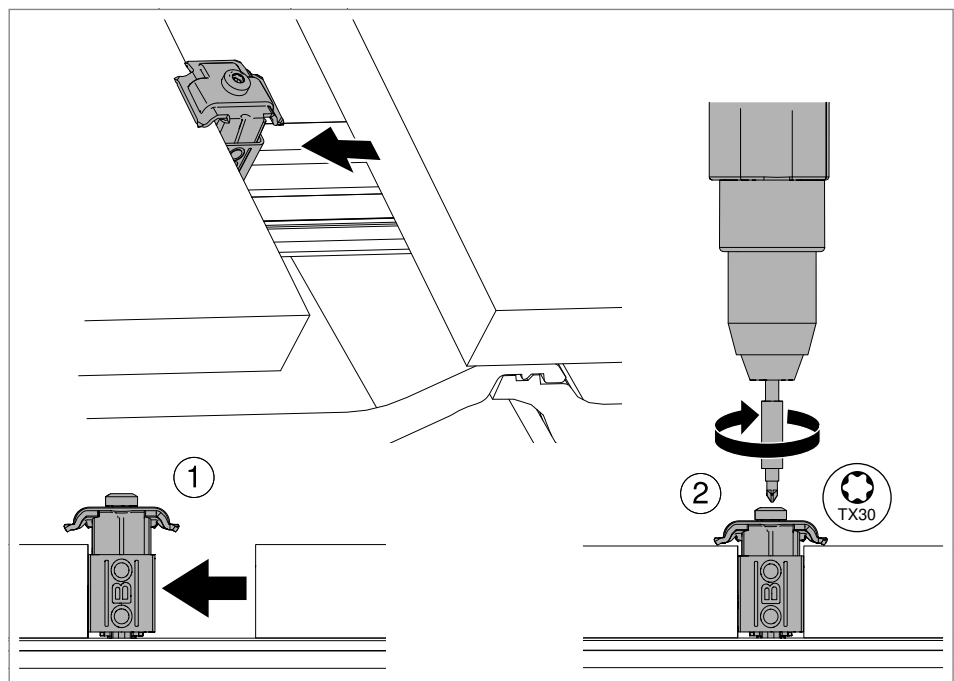

Fig. 20: Screwing on universal clamps as a middle clamp

2. Push the PV module up to the universal clamps up.
3. Screw in the universal clamp between the two modules with 8 Nm.

6.4.3 Mounting the universal clamp as an end clamp on the right

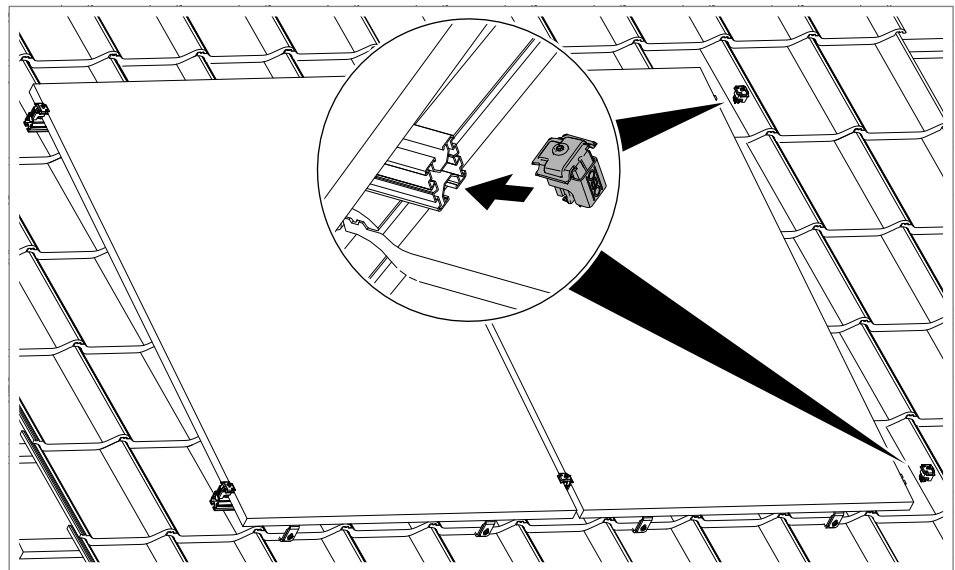

Fig. 21: Pushing the universal clamps in on the right as an end clamp

1. Push the universal clamps into the support profile from the right. The “OBO” label points outward.
2. Push the universal clamps up to the PV module.

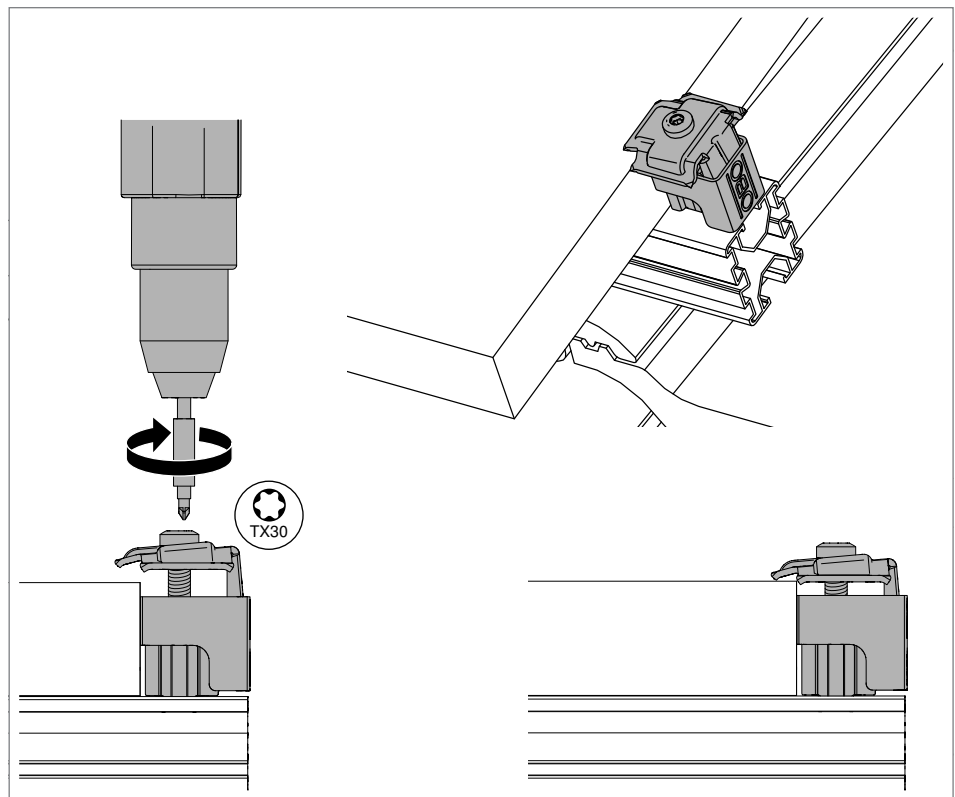

Fig. 22: Screwing the universal clamps in on the right as an end clamp

3. Screw the universal clamps to the outer edge of the module with 6 Nm.

6.5 Replacing the PV module

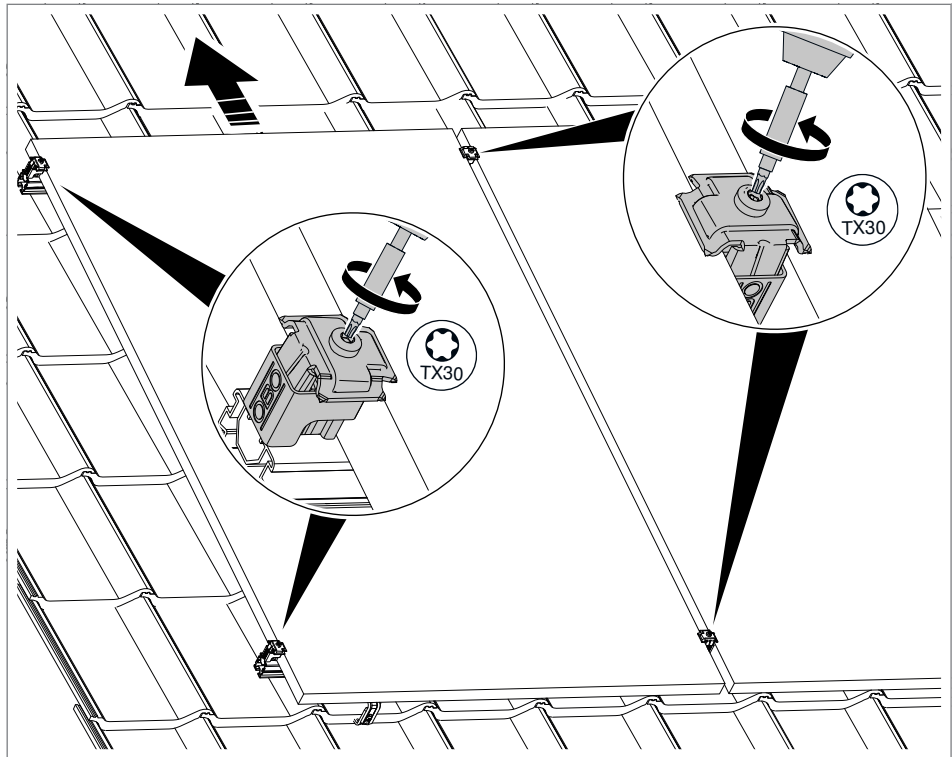

Fig. 23: Releasing universal clamps

1. Slightly unscrew the screws of the universal middle and end clamps.
2. Push the PV module upwards or downwards and out to exchange it.
3. Push in the new PV module.
4. Fasten the universal clamps with the prescribed tightening torque.

Note!

If the module cannot be pushed upwards or downwards and out, then the universal end clamps must be removed from the side of the support profile, in order to remove the module.

6.6 Fastening PV modules to Lehmann on-roof module holders

Depending on the tile type, on-roof module holders of make Lehmann can be used to avoid grinding the tiles and having to mount ceiling hooks. A retaining element is already installed on the on-roof module holder, on which the support profiles are mounted with a bolt and hammerhead nut, type SKS HM.

Note! *When mounting the on-roof module holder, the specifications and installation instructions of Lehmann must be observed.*

Note! *If larger uneven areas in the roof substructure have to be compensated for, the Lehmann on-roof module holders are not suitable, as they are not height-adjustable.*

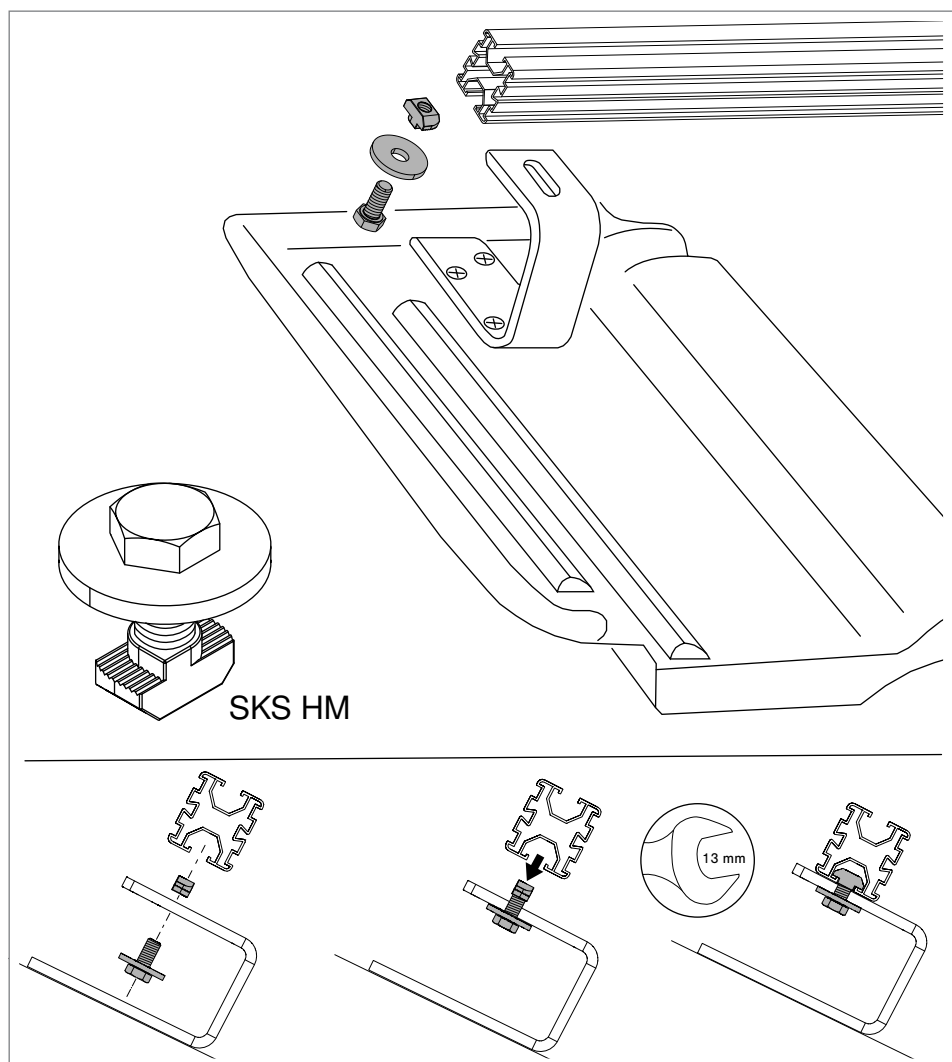

Fig. 24: Mounting the bolt with hammer nut

1. From below, push the bolt through the retaining element.
2. Lightly screw the hammer nut onto the screw from the top side of the retaining element.
3. Attach the support profile and tighten the screw so that the hammer nut engages in the support profile.

6.7 Mounting the protective cap

As protection against injuries and the ingress of dirt, the ends of the support profiles are closed off with protective caps.

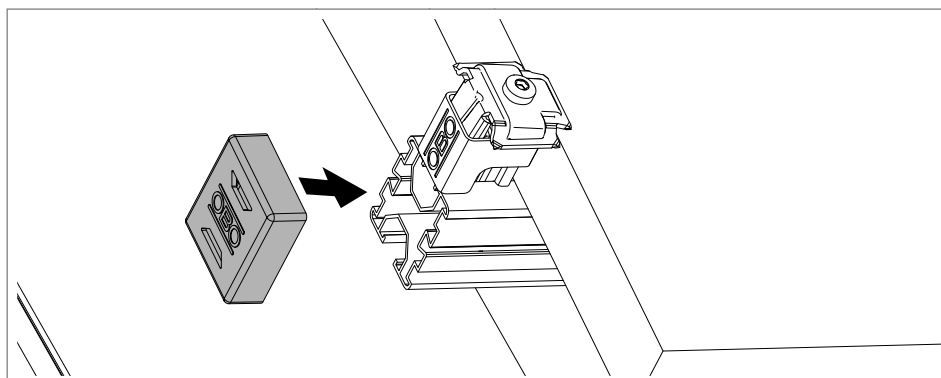

Fig. 25: Mounting the protective cap

1. Attach the protective cap at all the ends of the support profile and press it in.

6.8 Integrating the system into the equipotential bonding and/or lightning protection system

To ensure the safety of the PV system, it must be integrated into the equipotential bonding system. If the risk analysis according to DIN EN 62305-2 requires an external lightning protection system for the building, and if the separation distance between the PV system and the lightning protection system cannot be maintained, then both of these systems must be interconnected so that they can carry lightning current.

The universal earthing clamp can be used for both applications. The individual support profiles must be interconnected, in order to guarantee continuous, low-ohmic equipotential bonding.

A round conductor of \varnothing 8–10 mm and/or an equipotential bonding conductor of 6–50 mm² can be mounted on the universal earthing clamp.



WARNING

Risk of electric shock!

In the case of a lightning strike in the lightning protection system, lethal voltages can occur in the system. Do not work on the lightning protection system during a thunderstorm or if there is the risk of one.

1. If the support profile is anodised, then the anodisation must be scratched off in the area of the universal earthing clamp, so that a low-ohmic contact between the support profile and the earthing clamp is guaranteed.

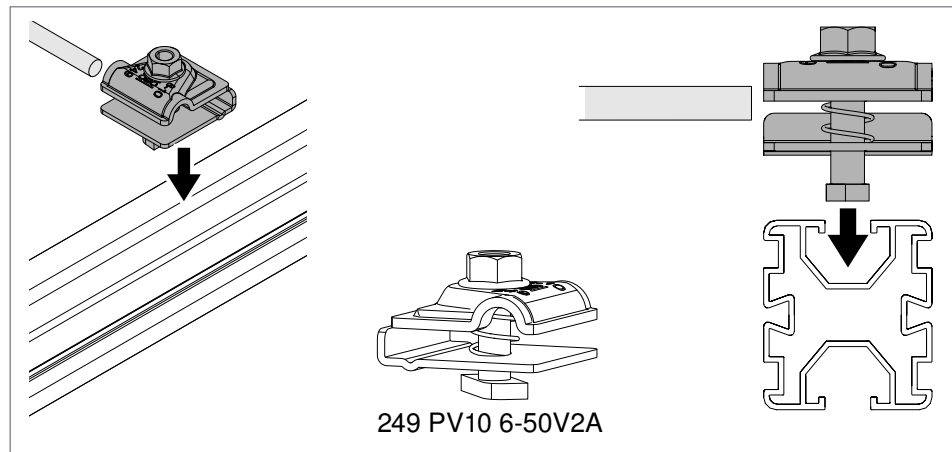

Fig. 26: Inserting the universal earthing clamp in the support profile

2. Insert the hammerhead bolt of the universal earthing clamp in the support profile.

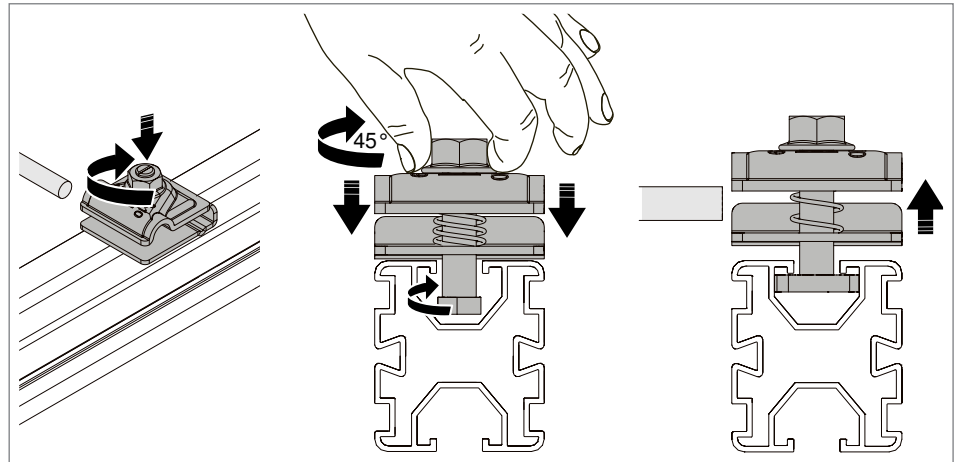

Fig. 27: Engaging the hammerhead bolt in the support profile

3. Push the hammerhead bolt with spring downwards, turn it through 45° and release it. In so doing, ensure that the hammerhead is firmly engaged in the support profile.

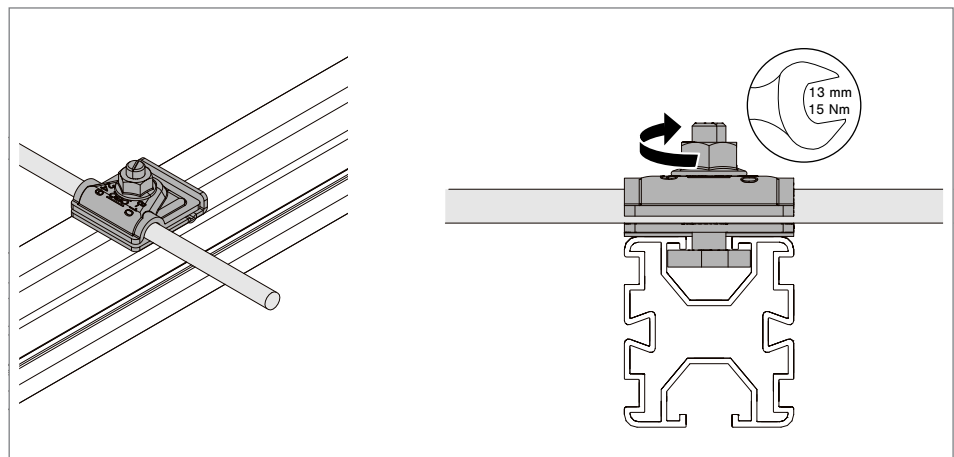

Fig. 28: Mounting the conductor in the universal earthing clamp

4. Insert the round conductor and/or equipotential bonding conductor.
5. Tighten the nut of the clamp with 15 Nm.

6.9 Mounting the support profile in a lengthwise direction

Support profiles can be connected lengthwise using straight connectors of type LV 45 DD. The length of a support profile must correspond to at least the distance between two adjacent rafters.

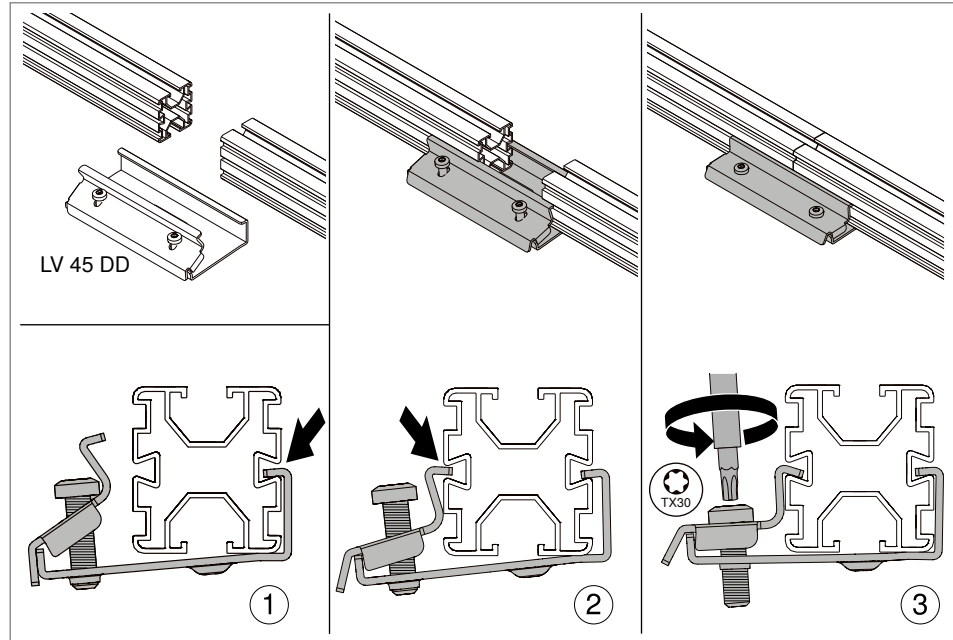

Fig. 29: Mounting a straight connector

1. Insert straight connectors in the groove on one side of the support profiles ①. The butt of the support profile must be located in the centre of the straight connector.
2. Hook the variable piece of the straight connector into the support profiles ②.
3. Tighten the screws on the straight connector with 6 Nm ③.

Note!

Alternatively, the support profiles can also be pushed into the straight connectors and the screws then tightened.

6.10 Connecting support profiles transversely

Support profiles can be connected transversely using cross-connectors of type KV 45 DD.

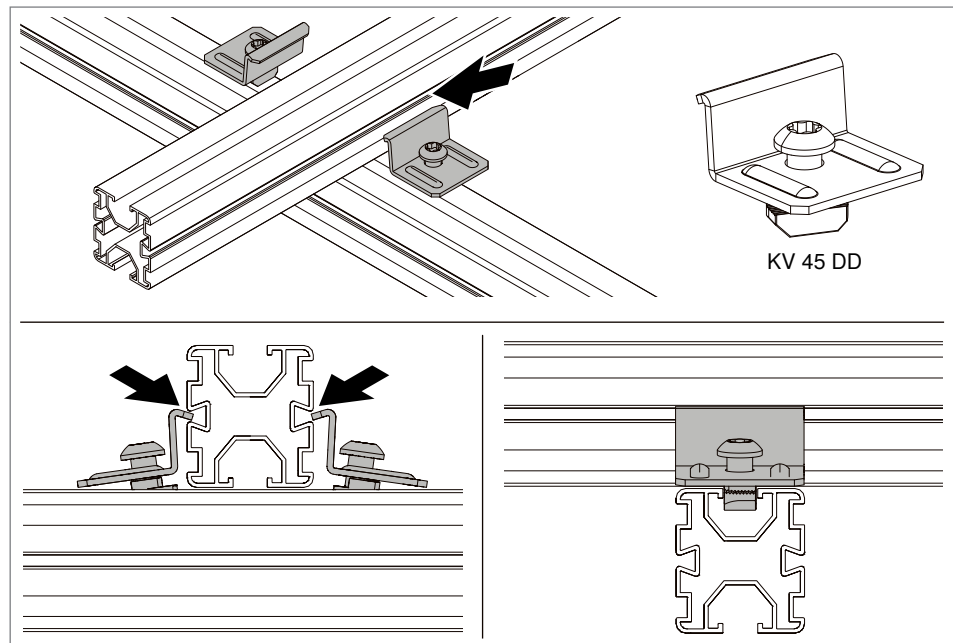

Fig. 30: Inserting cross-connectors

1. Insert cross-connectors with slide nuts into the lower support profile.
2. Hook the cross-connectors into the transverse support profile.

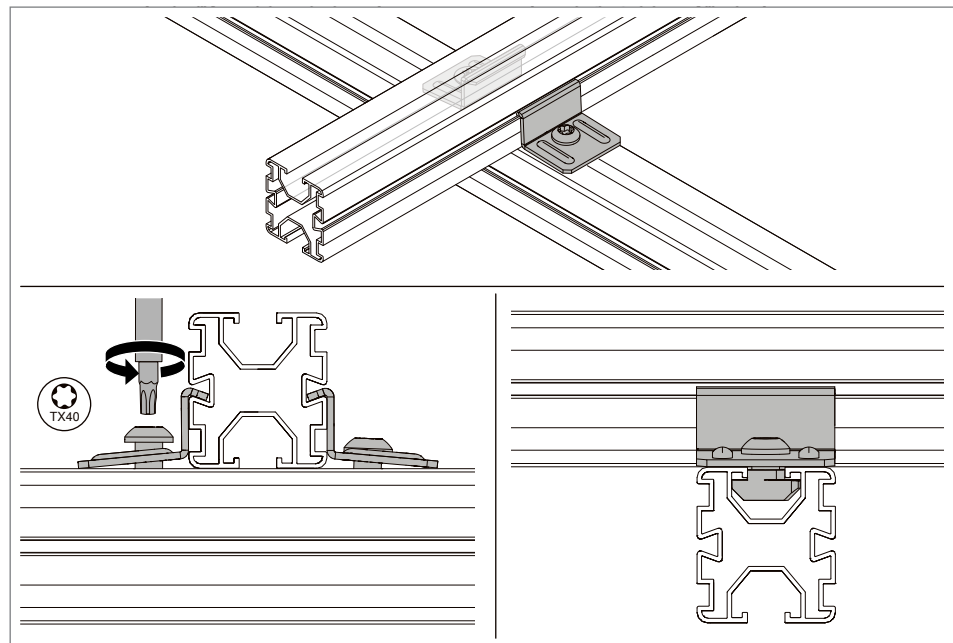

Fig. 31: Screwing on the cross-connectors

3. Tighten the screws on the cross-connectors with 6 Nm.

7 Maintaining the system

The PV mounting system is maintenance-free.

8 Dismantling the system

All the elements of the PV mounting systems are dismantled in the reverse order to the mounting. The universal clamp can be removed from the side of the support profile. The support profile can be removed from the ceiling hooks using a dismantling tool. The dismantling tool is included with the support profiles.

8.1 Dismantling a support profile

To be able to release the support profiles from the ceiling hooks, the dismantling tool must be used, which is included with the support profiles.

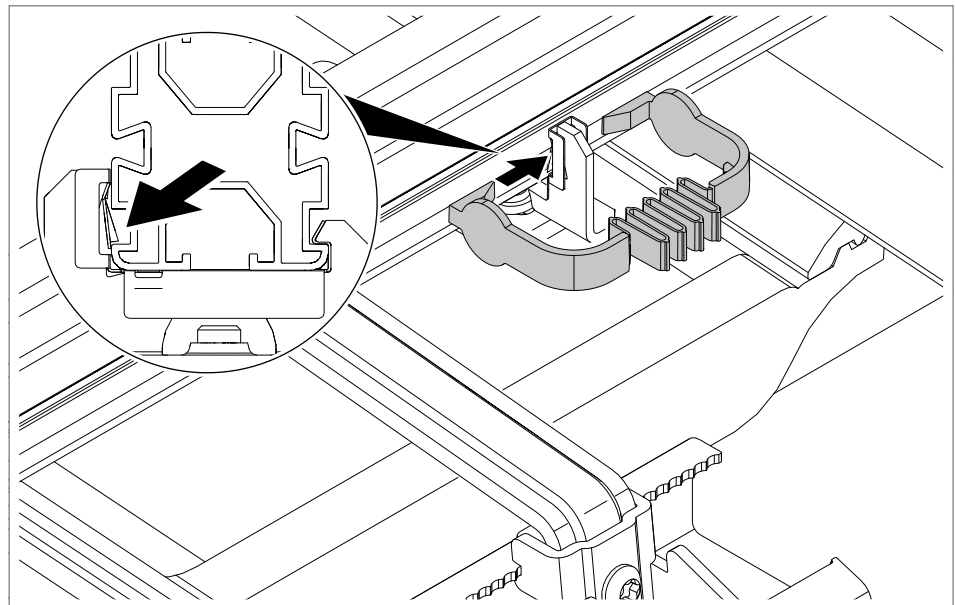

Fig. 32: Applying the dismantling tool to springs

1. Apply the dismantling tool to springs of the profile holder.

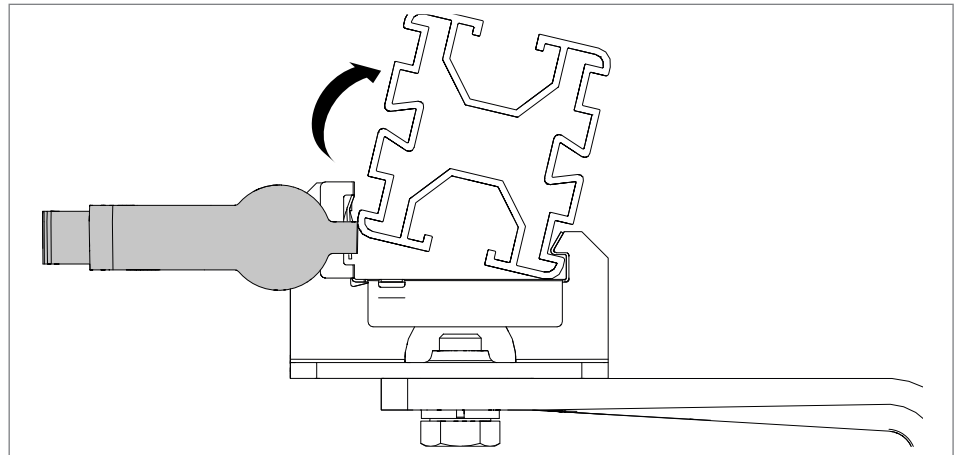

Fig. 33: Removing the support profile

2. Push in the dismantling tool.
3. Tilt and remove the support profile.

9 Disposing of the system

Comply with the local waste disposal regulations.

- Metal parts: As scrap metal
- Plastic parts/accessories: As plastic
- Packaging: As household waste/as metal (depending on packaging type)

10 Technical data

Designation	Type	Dimension mm	Material/surface	Article number
Support profile, for flat/pitched roof system	TP 45/2350 ALU	40 x 45 x 2350	Aluminium	5900405
Support profile, for flat/pitched roof system	TP 45/4700 ALU	40 x 45 x 4700	Aluminium	5900410
Support profile, for flat/pitched roof system	TP 45/4700ALU S	40 x 45 x 4700	Aluminium, black	5900412
Roof hook, universal, for pitched roof	DHU A2	140 x 197 x 144	Stainless steel A2	5901410
Universal clamp, for flat/pitched roof system	KLU A2	41 x 42 x 79	Stainless steel A2	5901010
Universal clamp, for flat/pitched roof system	KLU A2 S	41 x 42 x 79	Stainless steel A2 black	5901012
Bolt with hammer nut, for pitched roof system	SKS HM A2	Ø 28 x 24	Stainless steel A2	5901850

Designation	Type	Dimension mm	Material/ surface	Article number
Universal earthing terminal PV	249 PV10 6-50V2A	43 x 40 x 34	Stainless steel A2	5051520
End cap for support profile	EK 45 G	44 x 49 x 16	Polyethylene grey	5901722
End cap for support profile	EK 45 S	44 x 49 x 16	Polyethylene black	5901720
Wafer-head screw for pitched roof system	TKS 8x100 A2	Ø 20 x 104	Stainless steel A2	5901800
Wafer-head screw for pitched roof system	TKS 8x120 A2	Ø 20 x 124	Stainless steel A2	5901802
Wafer-head screw for pitched roof system	TKS 8x200 A2	Ø 20 x 204	Stainless steel A2	5901804
Straight connector for support profile	LV 45 DD	40 x 69 x 150	Steel doubledip	5901210
Cross-connectors for support profiles	KV 45 DD	30 x 40 x 40	Steel doubledip	5901250
Dismantling tool	Does not need to be ordered separately, included with the support profiles			

Tab. 3: Technical data

